

TECHNICAL MANUAL

OPERATOR'S MANUAL

EQUIPMENT
DESCRIPTION
page 1-2

OPERATING
INSTRUCTION
page 2-1

OPERATION UNDER
UNUSUAL CONDITIONS
page 2-14

CONTROLS AND
INDICATORS
page 2-1

GENERAL
OPERATOR
MAINTENANCE
page 3-1

PREVENTIVE
MAINTENANCE
CHECKS AND
TROUBLESHOOTING
PROCEDURES
page 3-2

OPERATION UNDER
USUAL CONDITIONS
page 2-5

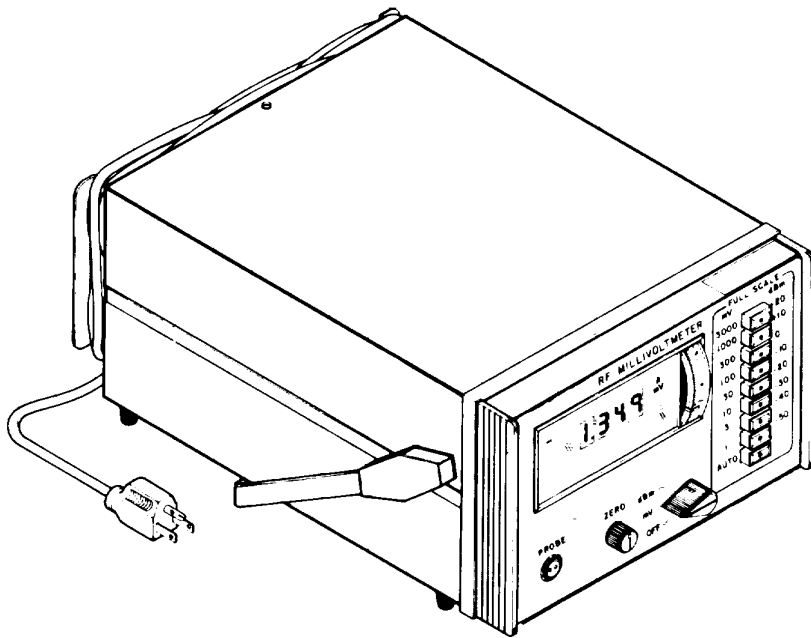

METER, RF MILLIVOLT ME-526A/USM
(NSN 6625-01-161-1461)

HEADQUARTERS, DEPARTMENT OF THE ARMY
28 MAY 1985

**5**

SAFETY STEPS TO FOLLOW IF SOMEONE
IS THE VICTIM OF ELECTRICAL SHOCK

1

DO NOT TRY TO PULL OR GRAB THE INDIVIDUAL

2

IF POSSIBLE , TURN OFF THE ELECTRICAL POWER

3

IF YOU CANNOT TURN OFF THE ELECTRICAL
POWER, PULL, PUSH, OR LIFT THE PERSON TO
SAFETY USING A WOODEN POLE OR A ROPE OR
SOME OTHER INSULATING MATERIAL

4

SEND FOR HELP AS SOON AS POSSIBLE

5

AFTER THE INJURED PERSON IS FREE OF
CONTACT WITH THE SOURCE OF ELECTRICAL
SHOCK, MOVE THE PERSON A SHORT DISTANCE
AWAY AND IMMEDIATELY START ARTIFICIAL
RESUSCITATION

A/B (blank)

OPERATOR'S MANUAL

**METER, RF MILLIVOLT, ME-526A/USM
(NSN 6625-01-161-1461)**

REPORTING ERRORS AND RECOMMENDING IMPROVEMENTS

You can help improve this manual. If you find any mistakes or if you know of a way to improve the procedures, please let us know. Mail your letter, DA Form 2028 (Recommended Changes to Publications and Blank Forms), or DA Form 2028-2 located in the back of this manual direct to: Commander, US Army Communications-Electronics Command and Fort Monmouth, ATTN.: DRSEL-ME-MP, Fort Monmouth, New Jersey 07703. A reply will be furnished direct to you.

		Page
	HOW TO USE THIS MANUAL	iii
CHAPTER	1. INTRODUCTION	
Section	I. General Information	1-1
	II. Equipment Description	1-2
	III. Technical Principles of Operation	1-7
CHAPTER	2. OPERATING INSTRUCTIONS	
Section	I. Controls and indicators I.....	2-1
	II. Preventive Maintenance Checks and Services.....	2-4
	III. Operation Under Usual Conditions.....	2-6
	IV. Operation Under Unusual Conditions.....	2-15
CHAPTER	3. OPERATOR MAINTENANCE	
Section	I. General Operator Maintenance	3-1
	II. Troubleshooting Procedures	3-2
APPENDIX	A. REFERENCES.....	A-1
APPENDIX	B. COMPONENTS OF END ITEM AND BASIC ISSUE ITEMS LISTS	B-1
Section	I. Introduction.....	B-1
	II. Components of End Item	B-2
	III. Basic Issue Items (Not applicable)	
APPENDIX	C. ADDITIONAL AUTHORIZATION LIST (Not applicable)	
	D. EXPENDABLE SUPPLIES AND MATERIALS LIST (Not applicable)	

HOW TO USE THIS MANUAL

This manual has been prepared in a sequentially numbered order of chapters and sections.

Each chapter contains sections given in Roman numeral order such as Section I, II, and III.

A table of contents is given at the beginning of each chapter for ready access to pages.

A bullet (●) indicates additional information needed for the paragraph above it.

A locator is provided on the right-hand border of the front cover. This gives the location in the manual of the Information most frequently needed.

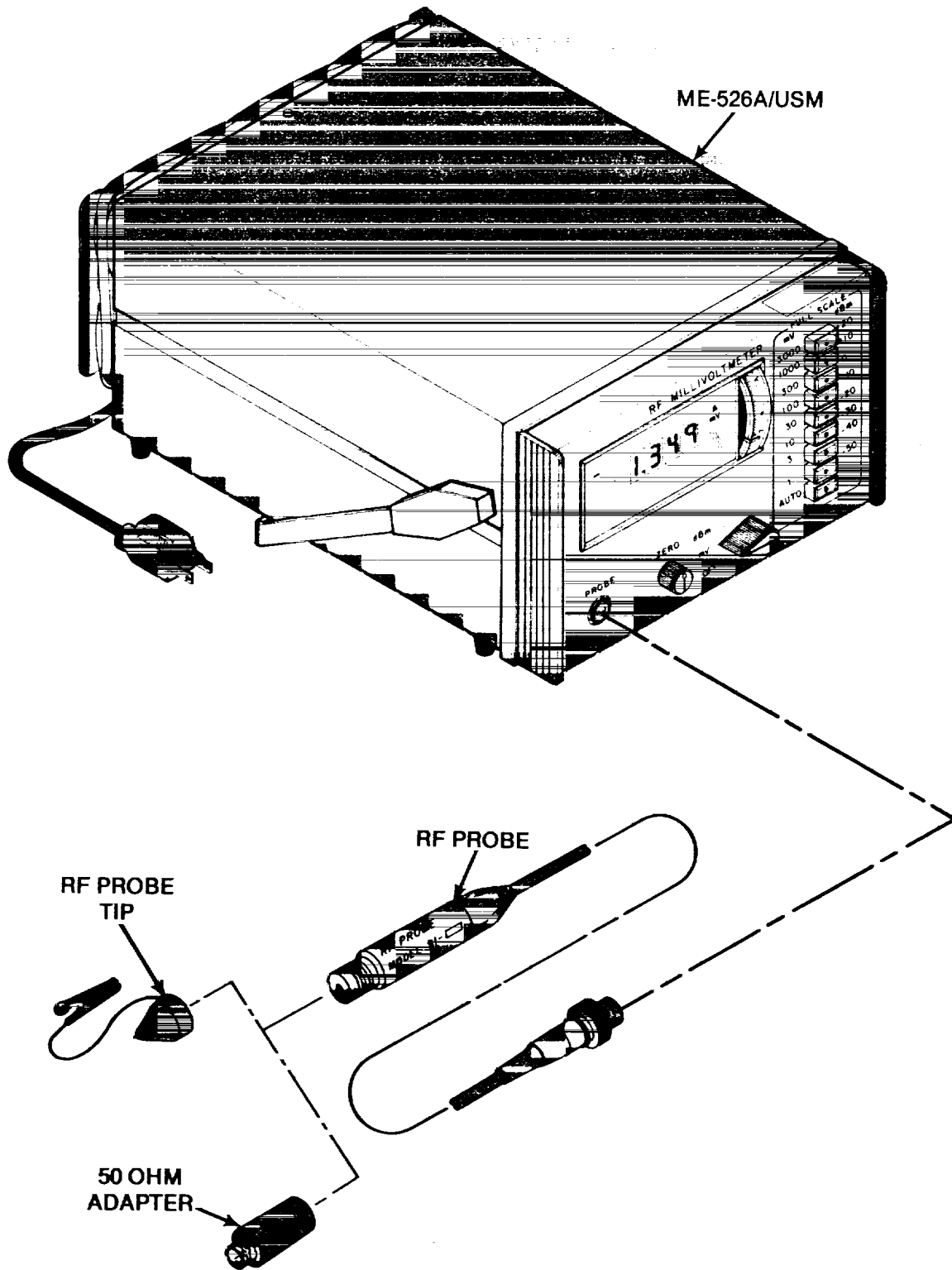

METER, RF MILLIVOLT ME-526A/USM

CHAPTER 1
INTRODUCTION

			Page
Section.	I.	General Information.....	1-1
Section.	II.	Equipment Description	1-2
Section.	III.	Technical Principles of Operation.....	1-7

Section I. General Information

SCOPE

- This manual covers operation and operator’s maintenance of Meter, RF Millivolt ME-526A/USM.
- The ME-526A/USM provides digital readout of rf voltages from 200 microvolts (uv) to 3.0 volts.

CONSOLIDATED INDEX OF ARMY PUBLICATIONS AND BLANK FORMS

Refer to the latest of DA Pam 310-1 to determine whether there are new editions, changes or additional publications pertaining to the equipment.

MAINTENANCE FORMS, RECORDS, AND REPORTS

Department of the Army forms and procedures used for equipment maintenance will be those prescribed by TM 38-750, The Army Maintenance Management System (TAMMS).

a. Reports of Maintenance and Unsatisfactory Equipment. Department of the Army forms and procedures used for equipment maintenance will be those prescribed by DA Pam 738-750, The Army Maintenance Management Systems (TAMMS).

b. Report of Packaging and Handling Deficiencies. Fill out and forward SF 364 (Report of Discrepancy (ROD)) as prescribed in AR 735-11-2/DLAR 4140.55/NAVMATINST 4355.73A/AFR 400-54/MCO 4430.3F.

c. Discrepancy in Shipment Report (DISREP)(SF 361). Fill out and forward Discrepancy in Shipment Report (DISREP) (SF 361) as prescribed in AR 55-38/NAVSUPINST 4610.33C/AFR 75-18/MCO P4610.19D/DLAR 4500.15.

REPORTING EQUIPMENT IMPROVEMENT RECOMMENDATIONS (EIR)

If your equipment needs improvement, let us know. Send us an EIR. You, the user are the only one who can tell us what you don’t like about your equipment. Let us know why you don’t like the design. Put it on SA 368 (Quality Deficiency Repot). Mail it to Commander, US Army Communications-Electronics Command and Fort Monmouth, ATTN: DRSEL-ME-MP, Fort Monmouth, NJ 07703. We’ll send you a reply.

DESTRUCTION OF ARMY ELECTRONICS MATERIEL

Destruction of Army electronics materiel to prevent enemy use shall be in accordance with TM 750-244-2.

Section II. Equipment Description

CHARACTERISTICS, CAPABILITIES AND FEATURES

- ME-526A/USM provides digital display of measurements from the low radio frequencies through approximately 1.2 gigahertz (GHz), over a voltage range of 200 microvolts (uV) to 3.0 volts.
- The ME-526A/USM exhibits true root mean square (rms) response for input signals up to 30 millivolts (m), gradually approaching peak-to-peak above this level. The digital voltmeter display is calibrated in rms above this level.
- The instrument has a high input impedance with stability, and low noise. A small edgewise dBm meter (used for reference and scale adjustment) is located on the front panel. This is used for zeroing the instrument on the lowest full scale range (the digital display blanks out below 200 uV).
- A binary coded decimal (BCD) output is provided at a rear recorder connector, permitting the ME-526A/USM to be integrated in systems for driving printers, tape or card punches, data control units, and similar interfacing data equipment. As part of a system, the ME-526A/USM is also programmed and controlled externally as needed.
- A linear direct current (dc) output, whose level is proportional to the radio frequency (rf) input voltage, is also provided at a rear connector. This may be used to drive a recorder remote indicator, or other analog device.
- Uses of the ME-526A/USM are:
 1. Transistor parameter measurements.
 2. Voltage standing wave ratio (vswr) and return loss measurements using the ME-526A/USM with bridge methods, directional couplers, and adjustable or slotted lines.
 3. Gain and loss measurements in wide-band amplifiers, including such design characteristics as stage gain, flatness of the pass band, upper cutoff or corner frequency, negative feedback factors, and other parameters.
 4. Adjustment of tuned circuits in narrow-band amplifiers.
 5. The adjustment, measurement of performance, and evaluation of parameters of rf filters.
 6. Measurement of vswr or return loss and attenuation of rf attenuators.
 7. Measurement of output levels of signal generators, adjustment of baluns, harmonic distortion of rf signals, and adjustment of circuits for minimum voltage (null) of maximum voltage (peak).

CHARACTERISTICS, CAPABILITIES AND FEATURES

- The standard features of the ME526A/USM are:
 1. Programmable (logic level).
 2. Measures from 200 microvolts (uV) to 3.0 volts from 10 kilohertz (kHz) to 1.2 GHz and 200 millivolts (mV) to 300 V up to 700 megahertz (MHz) using a 100 to 1.0 divider.
 3. True rms response 200 uV to 30 mV (to 3.0 V up to 700 Mhz using a 100 to 1.0 divider).
 4. Convenient pushbutton switches for ranging.
 5. BCD digital output plus dc analog output.
 6. High input resistance, low input capacitance.
 7. Overload protection to 400 volts dc (V dc), 10 volts (V ac).
 8. Vswr less than 1:1.15 up to 1.2 GHz.

EQUIPMENT DATA

- Weight and Dimensions

Weight	4.1 kg (9 lbs. 3 oz.)
Length	292 mm (11.5 in.)
Width	211 mm (8.3 in.)
Height	132 mm (5.2 in.)

- Radio Frequency Input

Input resistance: 500 k ohms to 10 k ohms (nominal)
 (100 kHz to 100 MHz)
 Accuracy: 1 mV to 3 V

Input Voltage	1% full scale (fs) plus			
300 mV to 3 V	1% rdg.	1% rdg.	3% rdg.	10% rdg.
200 uV to 300 mV**	2% rdg.			7% rdg.
	10 kHz	50 kHz	150 MHz	700 MHz
				1.2 GHz

*Below 1 mV, add 1% fs

- DATA PLATE

RF MILLIVOLTMETER
 ME - 526A/USM
 MFR 04901 SER NO.
 NSN 6625-01-161-1461
 CONTRACT DAAB07-82-G-H004
 US

CHARACTERISTICS, CAPABILITIES AND FEATURES

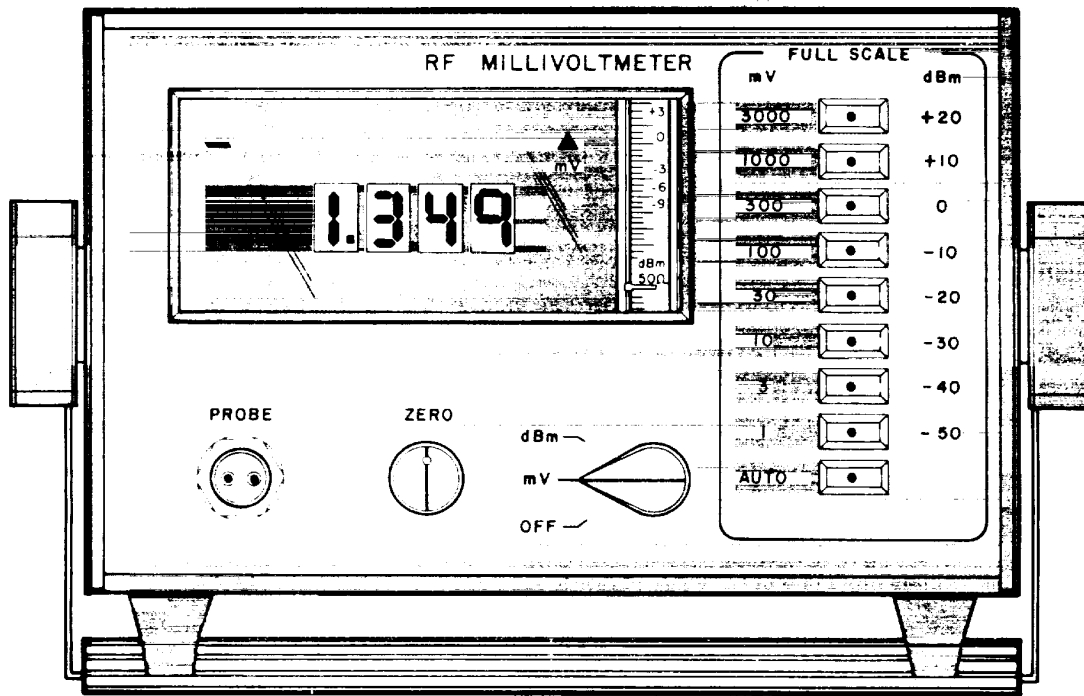

Front Panel

• **Voltage Range**

Millivolt

(FULL SCALE)	200 uV (min.) to 3.0 volts (max)
1	200 uV to 1.0 mV
3	1.0 to 3.0 mV
10	3.0 to 10.0 mV
30	10.0 to 30 mV
100	30 to 100 mV
300	100 to 300 mV
1000	300 mV to 1.0 volt
3000	1.0 to 3.0 volts

dBm meter range	- 9 to + 3 dBm Use only as reference
Frequency range	10.0 kHz to 1.2 Ghz
Temperature range	21° C to 25° C ± 0% of reading
	18° C to 30° C ± 1.0% of reading
	10° C to 40° C ± .0% of reading

CHARACTERISTICS, CAPABILITIES AND FEATURES

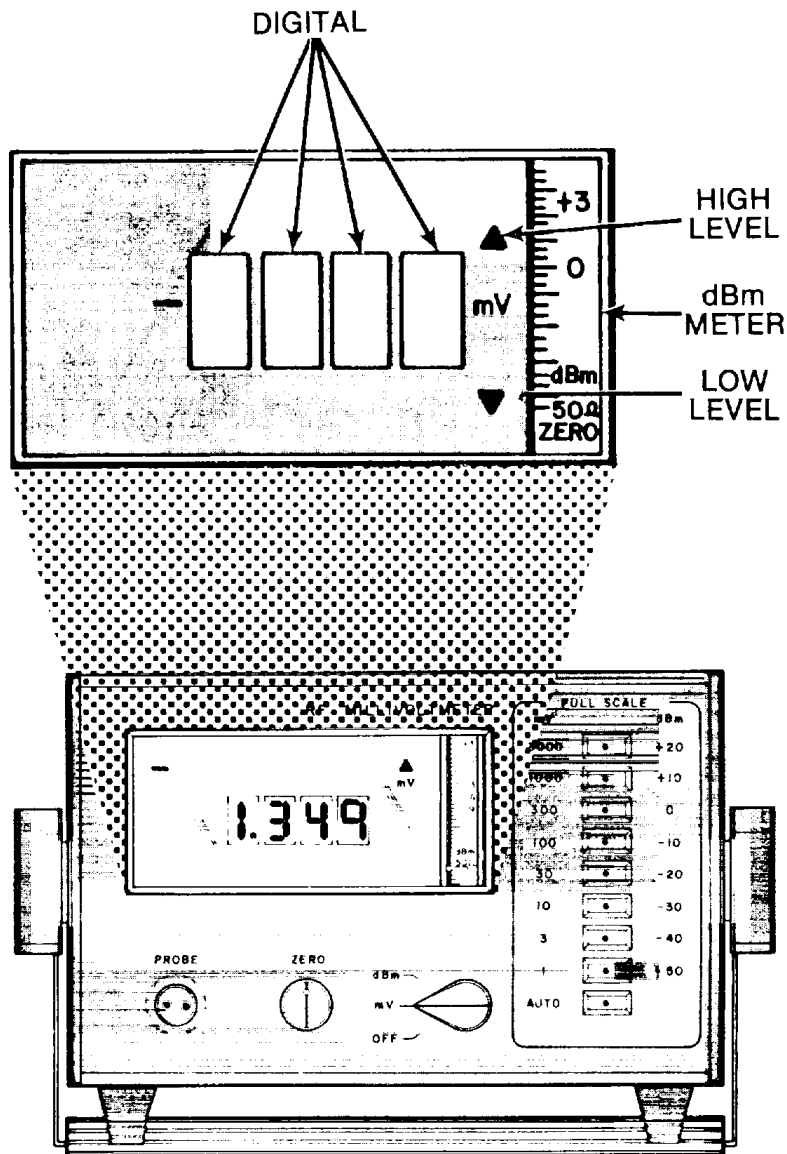

• Indicators

Digital



Light emitting diodes (LED's) present a 4 digit display with decimal point.

dBm meter

High level input signal. Increase FULL SCALE mV range pushbutton switch.
 Low level input signal. Decrease FULL SCALE mV range pushbutton switch.

Edgewise meter movement with meter scale of - 9 to + 3 dBm. Use only as reference.

CHARACTERISTICS, CAPABILITIES AND FEATURES

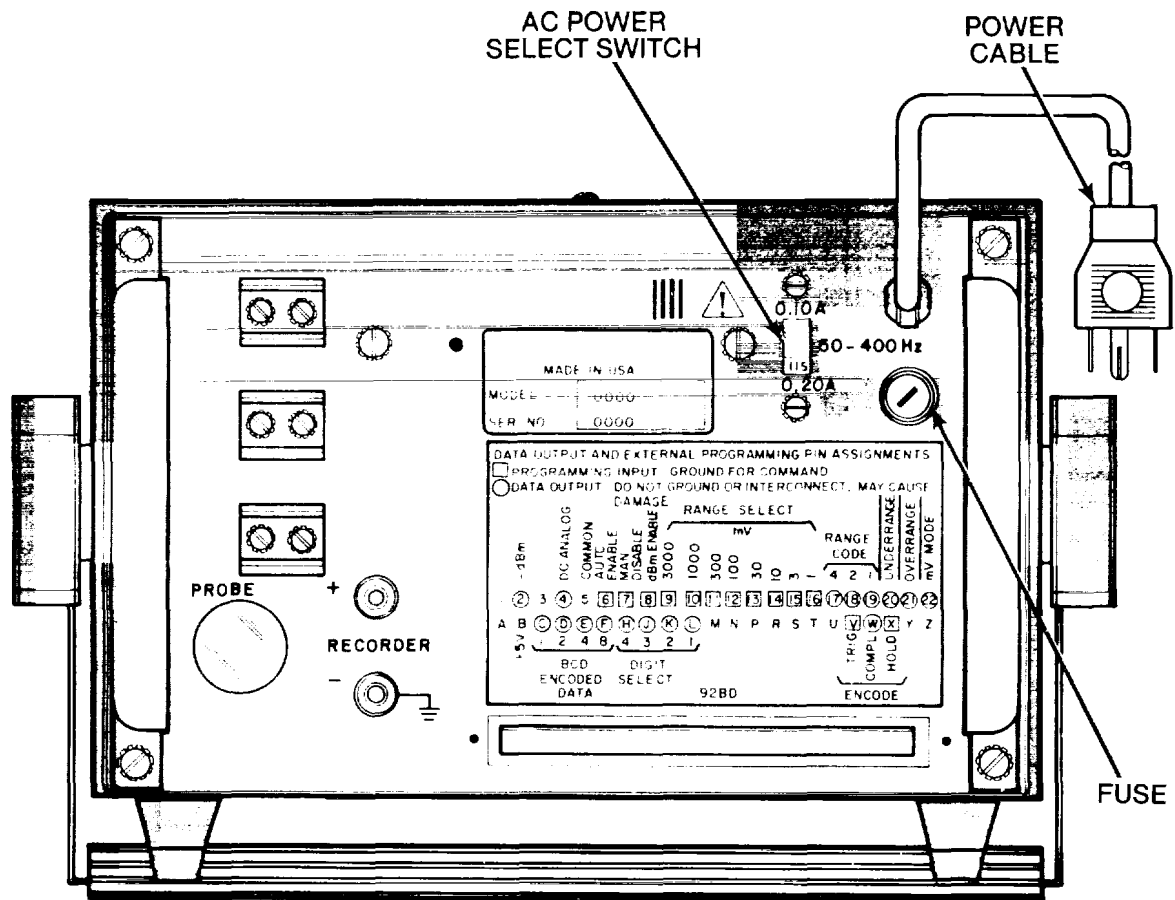

REAR PANEL

- **Ac Power Input**

115 volts ac 50 to 400 hertz (Hz) or 230 volts ac 50 to 400 Hz.

- **Fuses**

0.20 amp for 115 volts ac input power
 0.10 amp for 230 volts ac input power

Section III. Technical Principles of Operation

PRINCIPLES OF OPERATION

NOTE

The following functions shown on the front panel are not used or have limited use:

- The **dBm** position of the **OFF-mV-dBm** switch is not used.
- The **FULL SCALE AUTO** pushbutton switch is not used.
- The **FULL SCALE dBm + 20** thru - **50** scale is not used. May be used in conjunction with dBm meter for reference.
- The **dBm** meter is used for a zero level input reference and not for power measuring purposes.
-

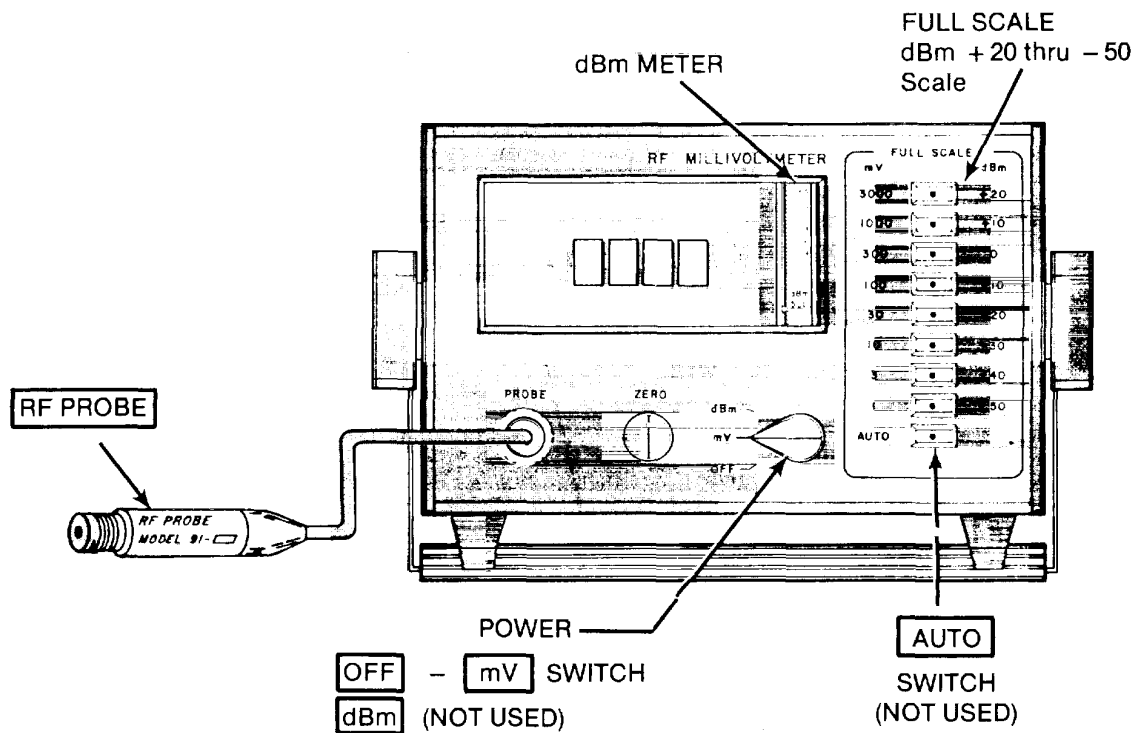

• **Power Switch**

Placing the **OFF-mV-dBm** switch in the mV position applies ac power.

• **RF PROBE and PROBE Input Connector**

When the **RF PROBE** is connected to an rf signal source the circuits in the **RF PROBE** rectify and filter the rf signal. The rectified and filtered rf signal becomes a dc voltage that is proportional to the rf signal source.1-7

PRINCIPLES OF OPERATION

- ZERO Control**

The **ZERO** control sets the sensitivity of the rf millivoltmeter. Since the rf millivoltmeter range is 200 uv to 3.0 volts the **ZERO** control is adjusted at the **FULL SCALE** mV 1 range which is the lowest and most sensitive range (200 uv to slightly more than 1 mV). **ZERO** adjustment is not needed on the 30 mV to 3000 mV ranges.

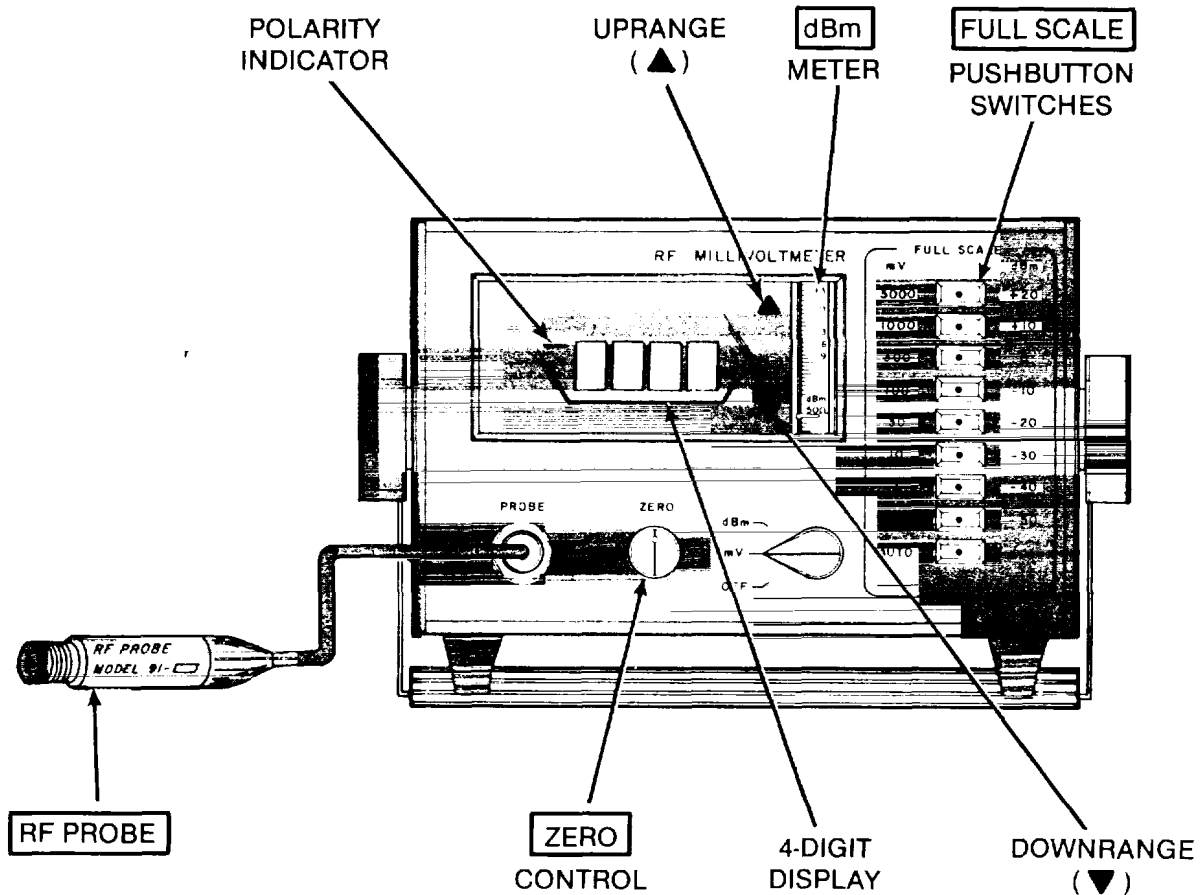

- FULL SCALE mV Pushbutton Swithes**

The **FULL SCALE 1, 3, 10, 30,100, 300, 1000, and 3000 mV** pushbutton swithes select the respective full scale reading that the rf millivoltmeter will display. For example, on the **1 mV** scale the amplitude of the signal under test (**RF PROBE** signal) will be displayed if it is between approximately 200 uV and 1.20 mV. Above or below this amplitude the digital display will go out (blank). On the **30 mV** range the signal under test (**RF PROBE** signal) will be displayed if it is between approximately 24.0 and 31.5 mV. The millivoltmeter display blanks when the **RF PROBE** signal is approximately 5% above or 20% below the full scale rf millivoltmeter display range selected.

PRINCIPLES OF OPERATION

- Downrange (▼) and Uprange(▲) Displays

When the **RF PROBE** signal level is below the range of the **mV** pushbutton selected the digital display will blank and a downrange (▼) display will appear. When the **RF PROBE** signal level is above the range of the **mV** pushbutton selected the digital display will blank and an uprange (▲) display will appear.

- **RF Millivoltmeter Display**

A 4-digit light emitting diode (LED) display provides the rf millivoltmeter voltage measurement. The voltage range of the display is selected by the **FULL SCALE mV** pushbutton switches (**1, 3, 10, 30, 100, 300, 1000** and **3000 mV** ranges). A decimal point can be displayed with three least significant digits.

- **Limited Use of dBm Meter and Polarity (-)(Indicator.**

a. Power level measuring circuits (dBm) have not been incorporated in the ME-526AIUSM. The **dBm meter** and the polarity (-) indicator operate and can be used for reference purposes. The **dBm meter** indicates relative signal strength in the **FULL SCALE mV** range selected. The down scale of the **dBm meter** (**ZERO** at the bottom of the scale) indicates a relatively low level input signal (for the scale selected). When switched to the lowest **FULL SCALE mV** range it is used to adjust the zero of the ME-526A/USM. As the **dBm meter** reading increases toward the top of the scale, the maximum for the range selected is approached. This is the point where the **mV** range switch must be increased. When the **dBm** reading approaches the bottom of the scale the **mV** range must be decreased.

b. The negative (-) sign at the left of the digital display would be used to indicate the power level of the signal under measurement should the dBm feature be installed in the ME-526A/USM. The negative (-) sign would be displayed when the indicator displays a power level below 1 milliwatt (0.0 dBm). When the negative sign is not present the indicator would display a power of 0.0 dBm or higher. Therefore, as the ME-526A/USM is used when the negative (-) sign just disappears, while adjusting the ZERO control with zero signal input, the sensitivity of the ME-526A/USM is set for zero with zero signal input. When the dBm feature is not installed and the ME-526A/USM is displaying only mV, the negative (-) sign indicates a negative zero offset when the input signal is zero. The ZERO control is adjusted so that the negative (-) sign just disappears.

PRINCIPLES OF OPERATION

- **Primary Alternating Current (Ac) Power Circuit**

The ME-526A/USM can be operated from a **115** or **230**-volt, **50** to **400**-Hz source. A slide switch, indicating **115** or **230**, connects the primary of the ME-526A/USM power transformer in parallel for 115-volt operation or series for 230 volt operation. A 0.20/A (ampere) fuse (115-volt operation) or a 0.10 A fuse must be installed.

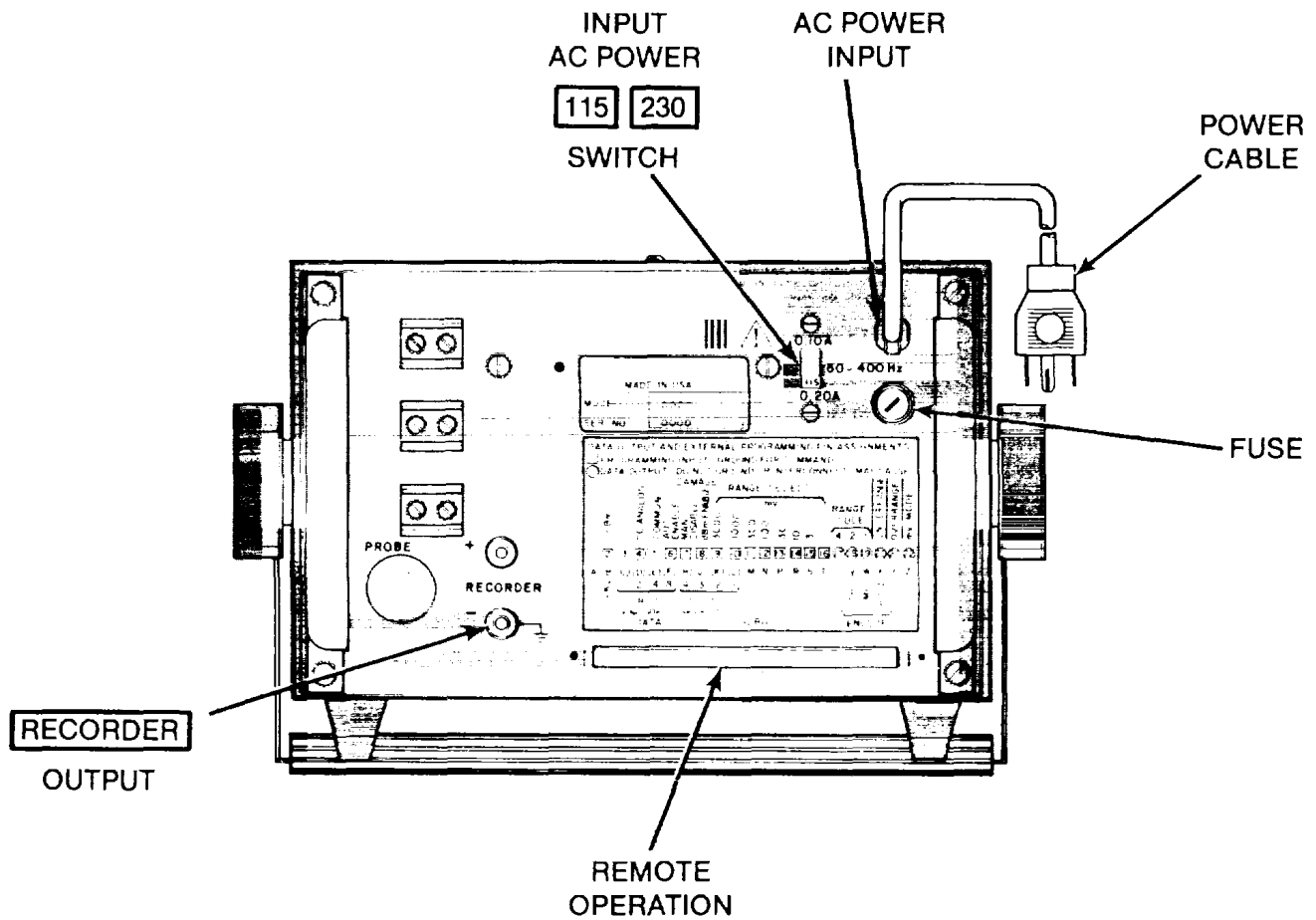

- **RECORDER Output**

A dc voltage is present at the **RECORDER** terminals that is proportional to the rf millivoltmeter digital display. When the digital display is full scale, the voltage at the **RECORDER** terminals will be 10 volts dc with the polarity marked on the front panel.

- **Connections for Remote Operation and External Programming.**

External connections can be made to the ME-526A/USM for remote operation and external programming. Additional equipment, not supplied with the ME-526A/USM, is required for this function.

CHAPTER 2

OPERATING INSTRUCTIONS

Section.	I.	Controls and Indicators.....	Page 2-1
Section.	II.	Preventive Maintenance Checks and Services(PMCS).....	2-4
Section.	III.	Operation Under Usual Conditions.....	2-6
Section.	IV.	Operation Under Unusual Conditions.....	2-15

Section I. Controls and Indicators

CONTROLS AND INDICATORS

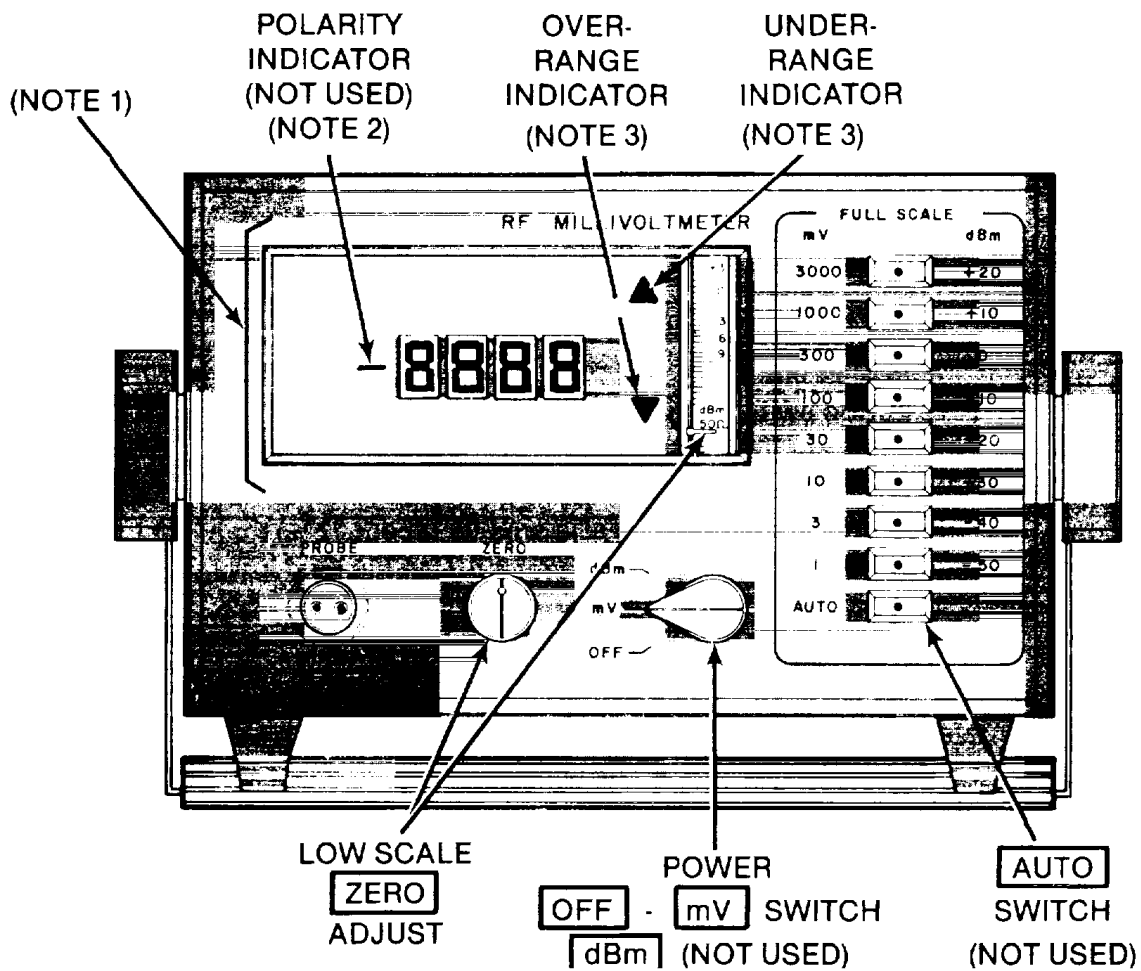

NOTES:

1. ALL INDICATOR ELEMENTS SHOWN LIGHTED.
2. POLARITY INDICATOR WILL EXTINGUISH WHEN RF MILLIVOLTMETER IS ZEROED.
3. ONLY UNDER - OR OVER - RANGE INDICATOR WILL LIGHT WHEN INDICATION IS REQUIRED.

CONTROLS AND INDICATORS

Front Panel

Function

OFF-mV-dBm switch

This switch turns on the ME-526A/USM power, and selects mV operation. The FULL SCALE dBm ranges are not used.

FULL SCALE range switches

These mV range pushbutton type switches (**1,3,10,30,100, 300,1000**, and **3000** and **dBm scale(- 50, - 40, - 30, - 2 - 10, 0, + 10, and + 20** not used) select the operating range. The AUTO pushbutton switch is not used.

Digital panel display

LED, 4 digits fs counts of 3000 and 1000. Full 4-digit display with 0.01 dB resolution. Blanked at 5% over and 20% below fs; decimal point and units.

dBm meter

Miniature edgewise type, Indicating - 9 to + 3 dBm, 50 ohms and zero. Meter indicator used for reference only.

PROBE (Jack)

The probe cable connector connects to the ME-526A/USM through the PROBE jack.

ZERO (Control)

This control is used to zero the ME-526A/USM. **Zero** is indicated on the scale of the **dBm** meter. Used with **FULL SCALE 1 mV** pushbutton switch.

♦ Indicator

Indicates input signal level is larger (about 5%) than **FULL SCALE mV** push-button switch engaged (pressed). Use the next higher **mV** switch.

◆ Indicator

Indicates input signal level is smaller (about 12%) than FULL SCALE mV push-button switch engaged (pressed). Use the next lower mV switch.

Polarity (-)
Indicator

Not used for other than zero adjustment of rf millivoltmeter digital panel display.

CONTROLS AND INDICATORS

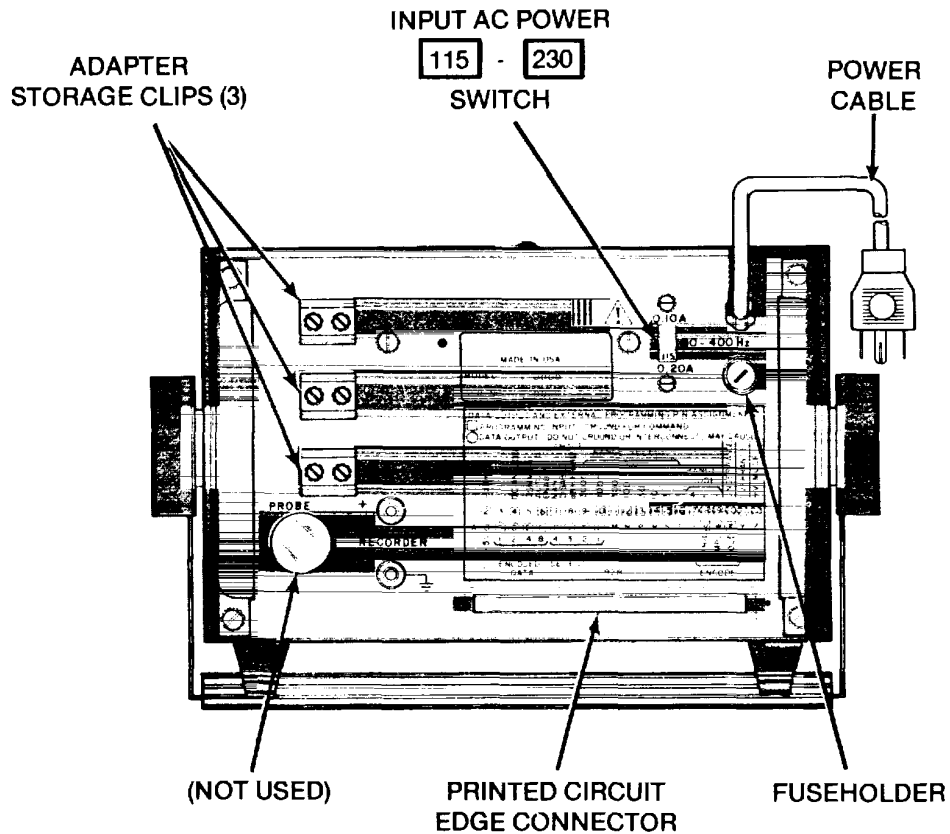

Rear Panel

Function

Fuseholder

A fuseholder is located on the rear panel containing either a 0.20 A, 115 V, or a 0.10 A, 220 V, Bussman **MDL SLO-BLO** fuse.

Input ac Power

Switch that is set to 115 or 230 (volts) according to the available power source.

115-230 switch

The proper fuse size is required.

RECORDER Output Terminals

A dc voltage proportional to the front panel indicator reading is available at these terminals. Fs output = + 10 V; output resistance = 9 k ohms.

Adapter Storage Clips (3)

Three storage clips are located at the rear panel for securing accessories and adapters which are not in use.

Printed Circuit Edge Connector

A card edge connector is mounted at the rear of the ME-526AIUSM.

This safety requirement symbol directs that it is necessary to refer to the instruction manual. In this case it is recommended that reference be made to the instruction manual when connecting the ME-526A/USM to the proper power source. It must be verified that the right fuse is installed for the power available and that the 10 A -0.20 A, 50400 Hz switch on the rear panel is set to the applicable operating voltage of 230 or 115 volts ac.

Section II. Preventive Maintenance Checks and Services (PMCS)

GENERAL

- **BEFORE YOU OPERATE**

Always keep in mind the CAUTIONS and WARNINGS. Perform your before (B) PMCS.

- **WHILE YOU OPERATE**

Always keep in mind the CAUTIONS and WARNINGS. Perform your during (D) PMCS.

- **AFTER YOU OPERATE**

Be sure to perform your after (A) PMCS.

- **IF YOUR EQUIPMENT FAILS TO OPERATE**

Check troubleshooting procedures.

- **ROUTINE CHECKS**

Routine checks such as cleaning, dusting, stowing items not in use and checking for loose nuts, bolts, mounting and the like are not listed as PMCS checks. You should do these things anytime you see they must be done.

NOTE

Use the **ITEM NO.** column in your PMCS table to get the number for the **TM ITEM NO.** column on DA Form 2404 (Equipment inspection and Maintenance Worksheet) when you fill out the form.

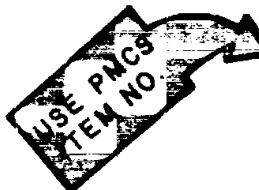

TM ITEM NO.	STATUS	DEFICIENCIES AND SHORTCOMINGS	CORRECTIVE ACTION	INITIAL WHEN CORRECTED
4		UNABLE TO ZERO AF MILLIVOLT METER BY ADJUSTING ZERO CONTROL.	SCHEDULED FOR EVACUATION	

DA FORM 2404
1 JAN 64

Preventive Maintenance Checks and Services (PMCS)

**B-BEFORE OPERATION
D-DURING OPERATION**

A-AFTER OPERATION

Item No	Interval			Item to be Inspected	Procedures Check for and have repaired or adjusted as necessary	Equipment is not ready/available if
	B	D	A			
1	•			Ac input power on rear panel	a. Verify voltage amplitude of available ac power (115+ 5, - 15 volts ac or 230+ 10 -20 volts ac) 50 to 400 Hz. b. Place input ac power 50-400 Hz switch in 115 or 230 position determined from a above. c. Check fuse in 50-400 Hz fuseholder. Fuse rating should correspond to 115 or 230 switch position marked on rear panel.	a. Power not available at proper voltage and frequency b. Not applicable c. Properly rated fuse not installed
2	•			ME-526A/USM and RF PROBE	Verify serial numbers of ME-526A/USM and RF PROBE are the same	Serial numbers are not the same
3	•			Signal to be measured is known to exceed 400 V dc or 3 V ac.	Divider required at ME526A/USM probe input (Divider not normally part of ME-526A/USM.)	Divider not available
4	•	•		ZERO adjust of ME-526A/USM	Short probe tip to ground. Depress. FULL SCALE 1 mV switch. Adjust ZERO control for ZERO reading on dBm edge meter.	Unable to zero rf millivolts meter by adjusting ZERO control for ZERO on dBm edge meter
5			•	ME-526A/USM	Store the RF PROBE , PROBE TIP and 50 OHM ADAPTER in the storage clips provided at the rear of the ME-526A/USM. The RF PROBE must not be replaced directly. See next column.	RF PROBE must be replaced Return ME-526A/USM to organizational maintenance The replacement RF PROBE must be calibrated to the ME-526A/USM with which it is used

Section III. Operation Under Usual Conditions

INITIAL CONNECTIONS AND ADJUSTMENTS

- Check the setting of the input ac power switch on the rear panel to be sure that it is set to the proper position for the ac power voltage available. Verify that the proper fuse is installed.
- Plug the power cable into a power receptacle.

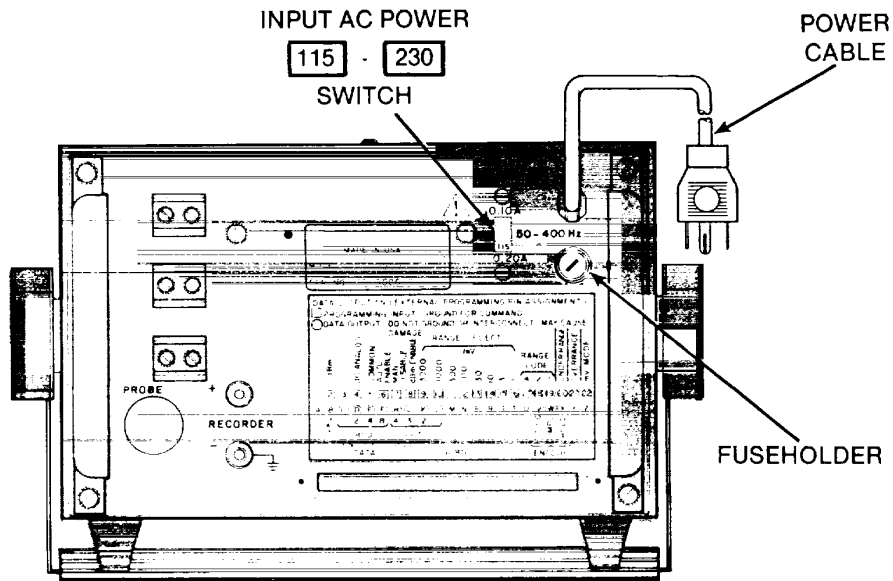

- Turn the OFF-mV-dBm switch to mV. Allow a minute for warm-up.

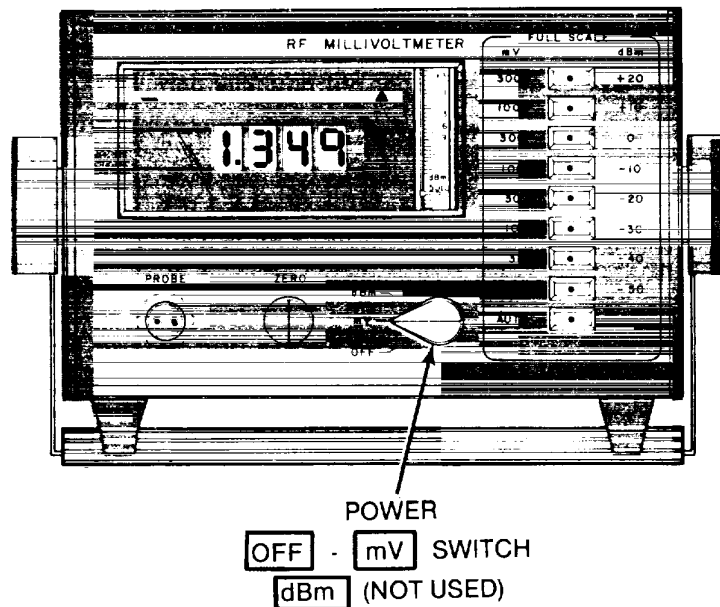

SELECTING PROPER RANGE

Connect the ME-526A/USM to the signal to be measured. Use the connection that is needed for the frequency to be measured.

- Note the rf millivoltmeter digital display. If the digital display is blank, an over \blacktriangle or an under \blacktriangledown range indicator will also appear.

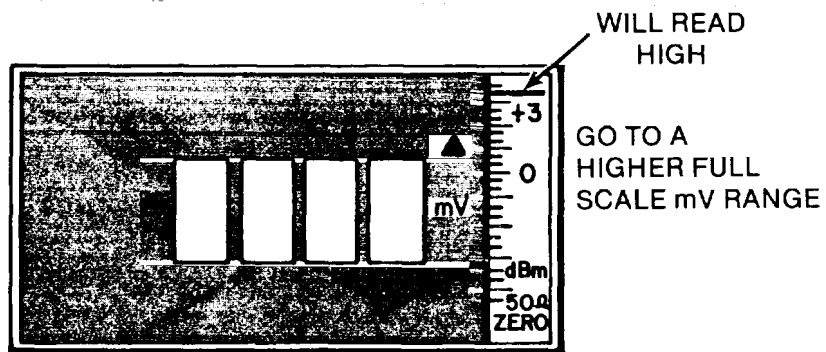
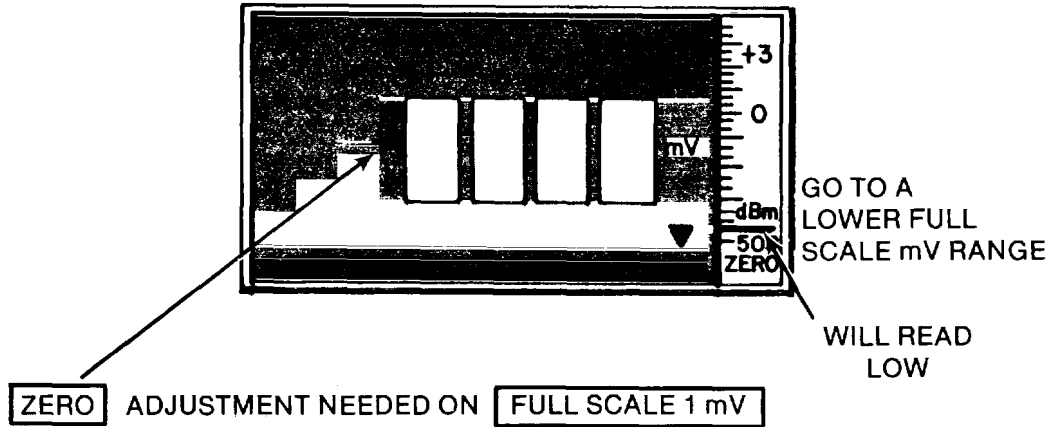

NOTE

When a large input signal is applied to the **RF PROBE**, a relatively long period of time may be needed before accurate measurement can be made. This is caused by ME-526A/USM circuit saturation and by the high amplitude of the input test signal (the input signal under test by the ME-526AUSM).

Operating Procedures

NOTE

Be sure that the serial number of the rf probe to be used is the same as that of the M E-526A/USM. (Each ME-526A/USM is alined with its RF PROBE.) Use of a probe other than that for which the ME-526A/USM was alined may result in measurement errors.

- Connect the **RF PROBE** cable to the **PROBE** jack on the front panel.
-

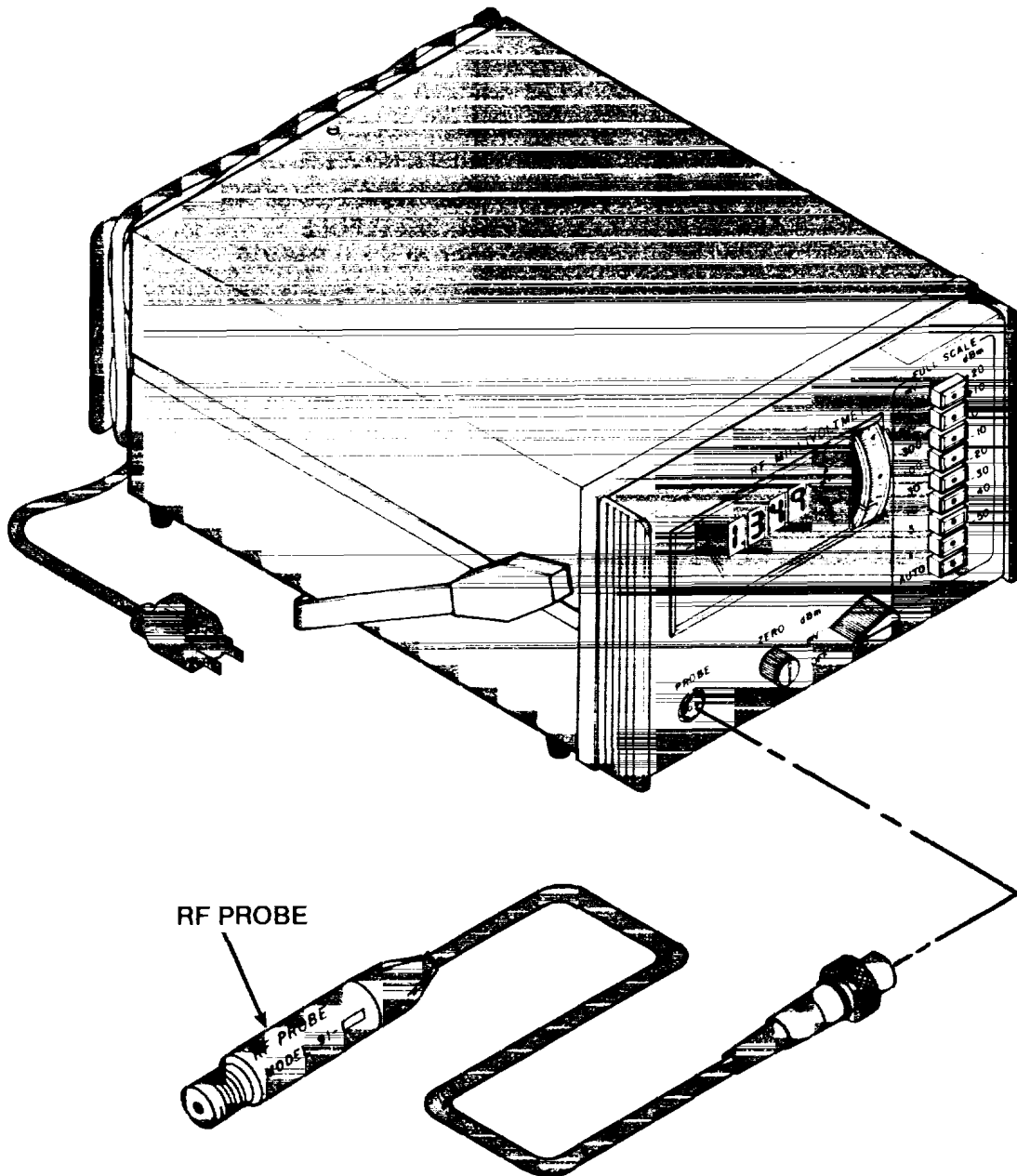

Operating Procedures

Press the **FULL SCALE 1 mv** pushbutton switch. The **dBm** meter pointer should rest on the **ZERO** reference line. If it does not connect the **50 ohm ADAPTER** to the **RF PROBE** and use the **ZERO** control to set the pointer to the **ZERO** reference line on the **dBm** meter. The negative sign (-) on the display should disappear.

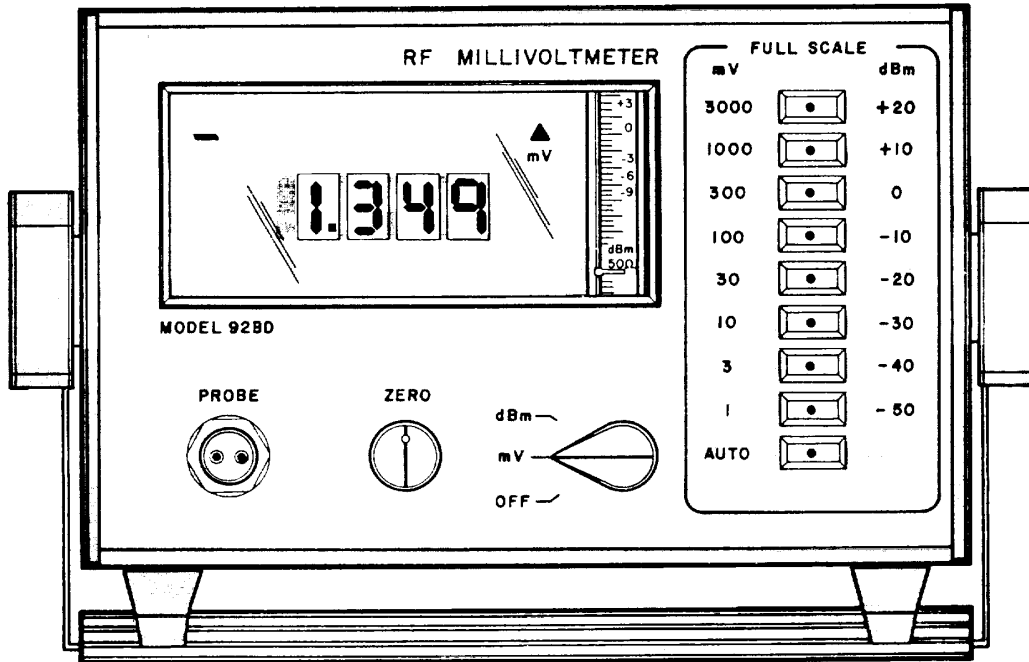

VOLTAGE RANGES (mV) AND CREST FACTORS

VOLTAGE RANGES (mV)	1	3	10	30	100*	300*	1000*	3000*
CREST FACTOR**	420	70	21	7	420	70	21	7
	to	to	to	to	to	to	to	to
	42	14	4.2	1.4	42	14	4.2	1.4

*With accessory 100:1 Voltage Divider

**Maximum permissible ratio of peak to rms value of voltage.

Operating Procedures

CAUTION

Do not connect the RF PROBE to a circuit that exceeds 10 volts ac or 400 volts dc.

CAUTION

When the 50-OHM ADAPTER is used, do not continuously apply more than 10 volts that is the sum of dc and rms ac applied.

- Measurement of rf voltage below 100 MHz.

The **RF PROBE** is equipped with a detachable tip and ground lead. For measurements of signals below approximately 100 MHz, this tip provides a convenient means for both signal and ground connection.

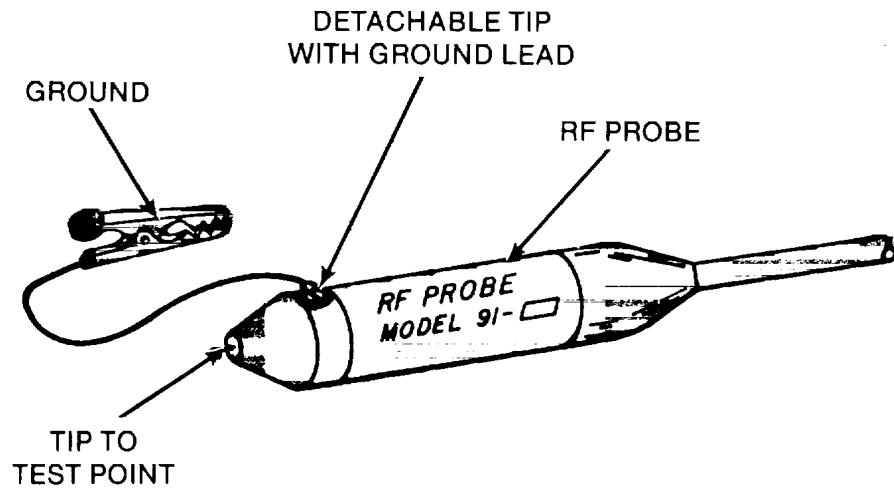

Operating Procedures

- Measurement of rf voltage from 100 MHz to 250 MHz.

For measurements at frequencies from 100 MHz to 250 MHz the **RF PROBE** tip should not be used. Connections should be made directly to the center contact of the **RF PROBE** with the ground connection kept as short as possible.

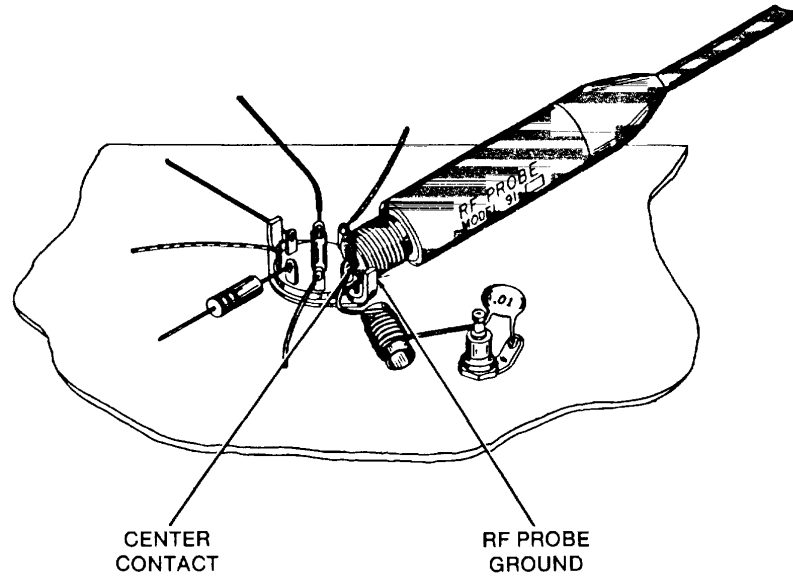

Operating Procedures

- Measurement of rf voltage from 250 MHz to 600 MHz.
 1. For measurements at frequencies from 250 MHz to 600 MHz the **RF PROBE** is used with the **50 OHM ADAPTER**. A coaxial cable must be fabricated to connect the **50 OHM ADAPTER** to the signal to be measured. Refer this requirement to your organizational maintenance facility.

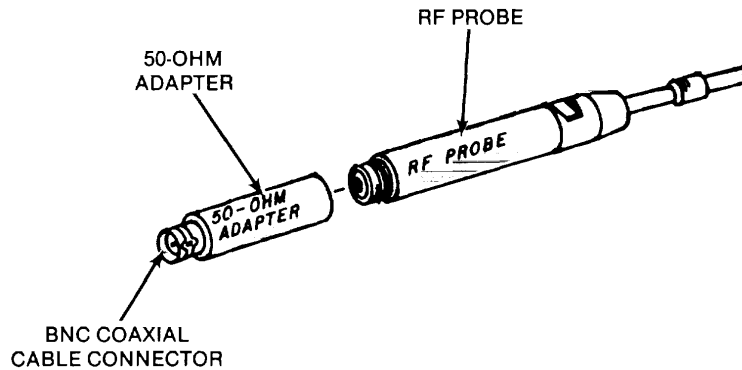

2. The graph below indicates the percentage of the digital meter reading that must be added to the meter reading when the **50-OHM ADAPTER** is used.

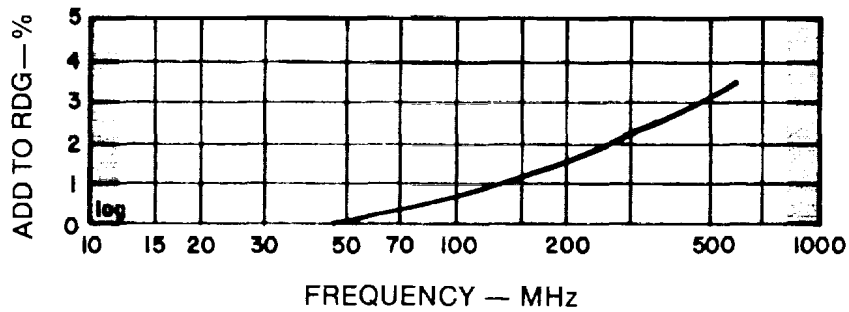

3. Typical voltage standing wave ratio (VSWR) of the **RF PROBE** when used with the **50 OHM ADAPTER** is plotted in the graph below.

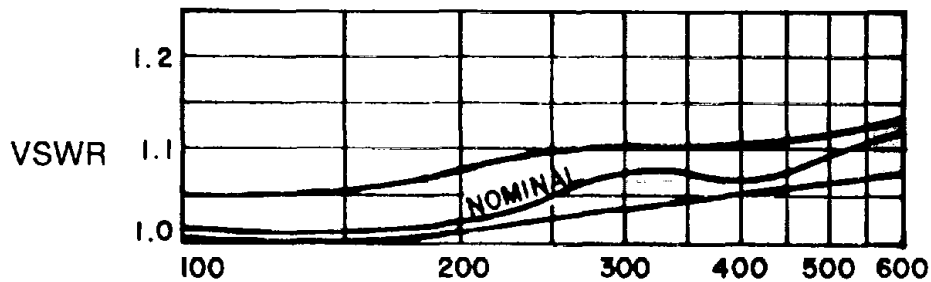

Operating Procedures

- Measurement of rf voltage above 600 MHz.
 1. For measurements at frequencies above 600 MHz the **RF PROBE** must be used with a type N T ADAPTER, a 50-ohm termination and a fabricated coaxial cable for connection to the signal to be measured. Refer this requirement to your organizational maintenance facility.

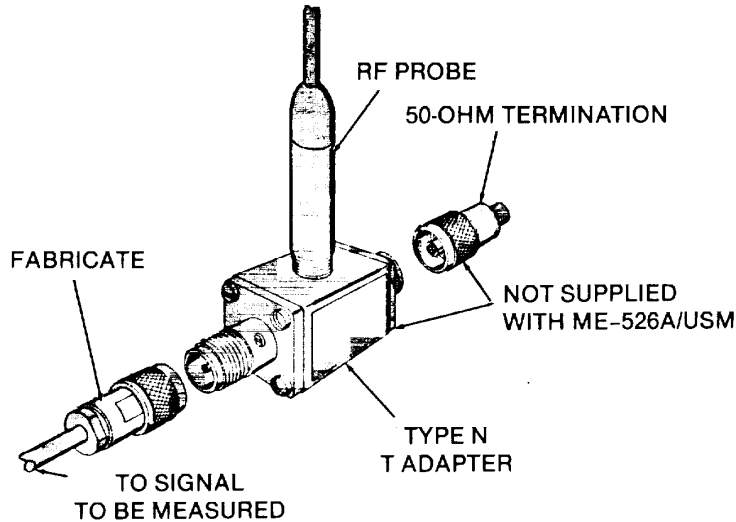

2. Type N T Adapter Correction Curve is shown below. (Input voltage to T Adapter is indicated by voltmeter.) Subtract the correction from the indicated value, in dB, to obtain output voltage of T Adapter.

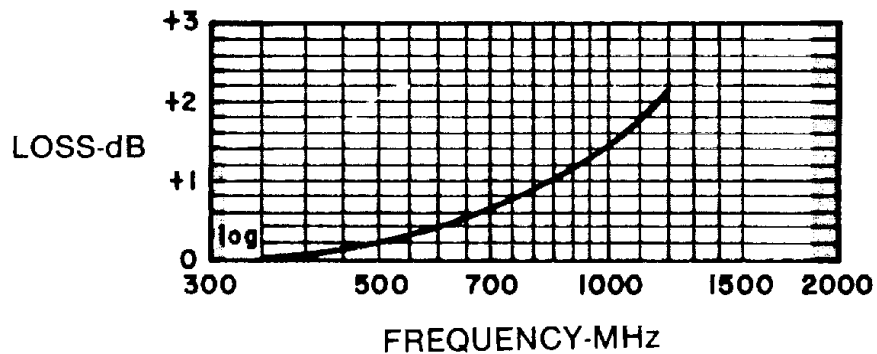

3. Typical VSWR of the **RF PROBE** with a type N T Adapter and 50-ohm termination is shown below.

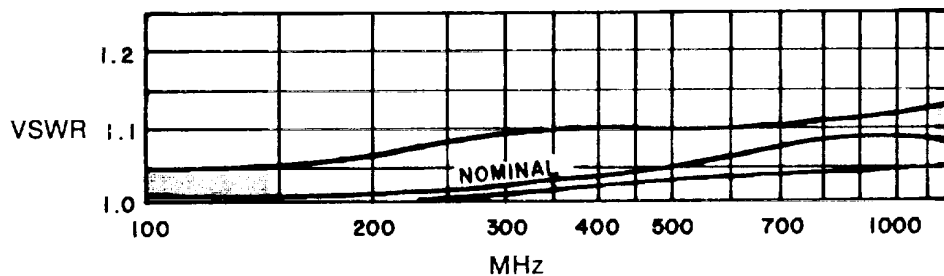

Operating Procedures

- Measurement of rf voltage at levels below 30 mV 1, 3, and 10 **FULL SCALE mV**.

For accurate measurements of rf voltages at levels using the 1, 3, and 10 **FULL SCALE mV** pushbutton ranges, zero the rf millivoltmeter on 1 mV range.

NOTE

Stray pick-up of rf in areas where strong rf fields exist may cause erratic reading on the digital millivoltmeter when the **FULL SCALE 1 mv** and 3 pushbutton ranges are used.

1. Attach **50-OHM ADAPTER** to **RF PROBE**. Disconnect rf input from **50-OHM ADAPTER**.

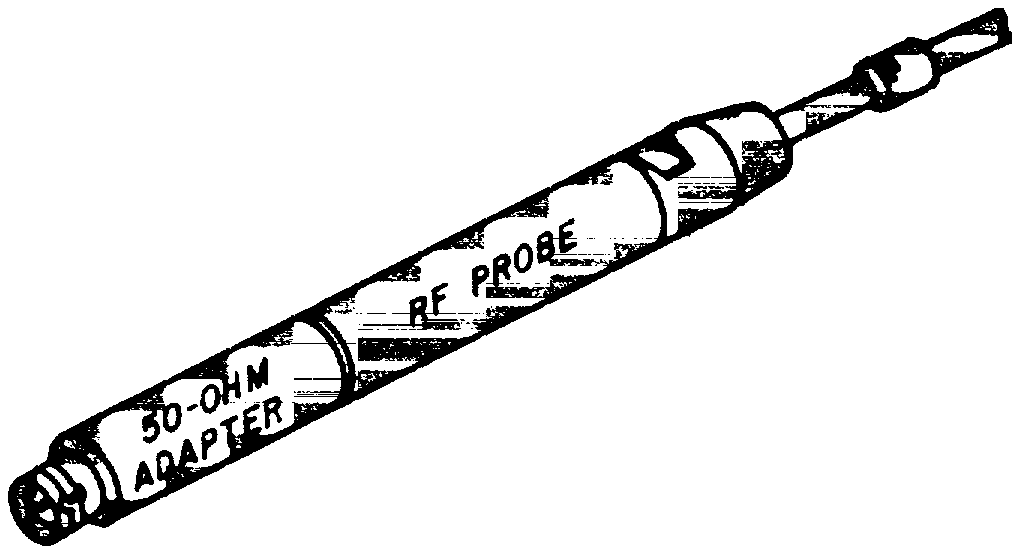

2. Press **FULL SCALE 1 mV** pushbutton.
3. Adjust **ZERO** control for **ZERO** on **dBm** meter and adjust so that negative (-) sign on the display just disappears.

Section IV. Operation Under Unusual Conditions

Operation of meter RF Millivolt ME-526A/USM in an area with high rf radiation, extreme ambient temperatures and high moisture (humidity) conditions are considered unusual conditions. The ME-526A/USM is normally used in an electronics laboratory or a maintenance facility.

- **Operation in area with high rf radiation.**

Minimize rf radiation effects by:

1. Moving to another location within work facility.
2. Repositioning equipment under test and the ME-526A/USM.

- **Operation in extreme ambient temperatures.**

Operation at a temperature below 10°C (50°F) or a temperature above 40°C (104°F) will produce inaccuracies in measurements.

- **Operation In high humidity conditions.**

Humidity affects the dielectrics of rf components and therefore will result in incorrect measurements. Operation should stop until humidity becomes normal.

INTERFACE INFORMATION

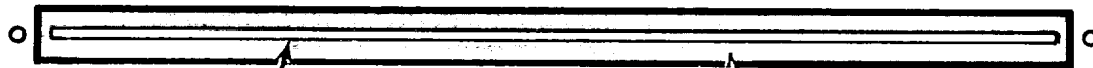
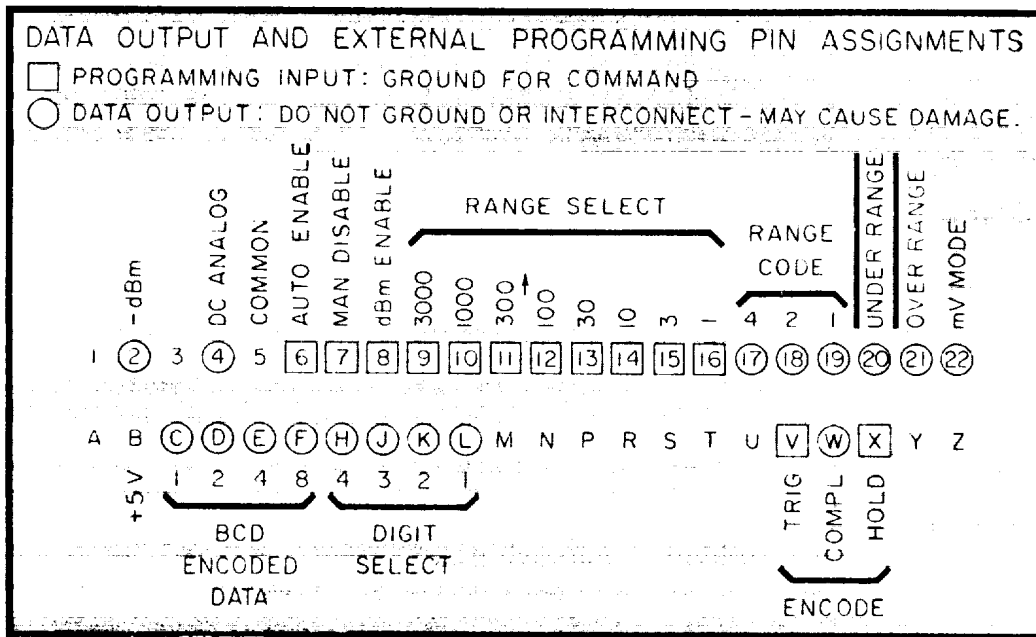

PRINTED CIRCUIT BOARD
EDGE CONNECTOR

PINS 1-22 (ON TOP)
PINS A-F, H, J-N, P, R-Z
(ON BOTTOM)

INTERFACE INFORMATION

- Programming Inputs**

Programming inputs to pins of the edge connector are listed in the chart below.

<i>Pin No.</i>	<i>Function</i>	<i>Comment</i>	<i>Command</i>	<i>54/74 Unit Load</i>
7	MAIN DISABLE	Disables front panel FULL SCALE 1 thru 3000 mV range selection.	0	0.1
8	dbM ENABLE	Not Used.		
6	AUTO ENABLE	Not Used.		
16	1	Selects input signal range provided MANUAL DISABLE has also been selected. Selecting more than one range will result in incorrect indications. All range lines (pin 9 thru 16) must be open for front panel operation.	0	0.1
15	3		0	0.1
14	3		0	0.1
13	30		0	0.1
12	100		0	0.1
11	300		0	0.1
10	1000		0	0.1
9	3000		0	0.1
X	ENCODE HOLD	Holds display	0	0.2
V	Encode trigger (TRIG)	Starts encode cycle	1 to 0 transition	0.1

- **Input Characteristics**

<i>TTL Series</i>	<i>Logic Level</i>	<i>Voltage Level</i>	<i>Current per Unit Load</i>
Standard Power 54/74	0	less than 0.7 V	-1.6 mA*
	1	2.4 to 5.25 V	40 uA

*The "-" current indicates that current out of the input (external command device) must sink (absorb this current). A standard power (Series 54/74) TTL output will sink and source 10 unit loads.

- **Input Current**

All input terminals have Internal current. The current sourced by this current when the input is brought to a logic level 0 is included in the loading shown in the Current per Unit Load column of the chart above.

- **Triggering**

To trigger an encode cycle, the trigger line must be transferred from logic "1" to logic "0". Limits for trigger pulse characteristics are shown below.

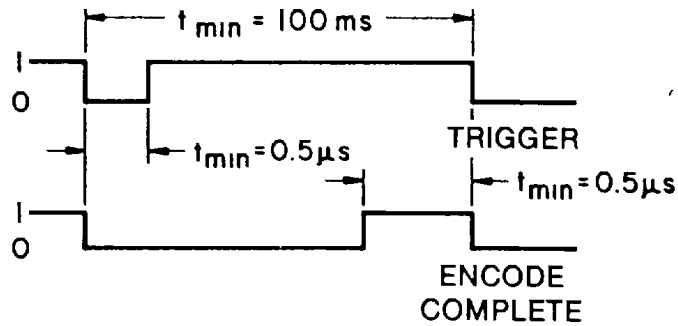

• **Data Outputs**

Data outputs from pins of the edge connector are listed in the chart below.

<i>Pin No.</i>	<i>Function</i>	<i>Comment</i>	<i>True Logic Level</i>	<i>54/74 Unit Load</i>	
22	mV MODE	Indicates voltage display 10 V for full scale of "1" ranges; 0.5 V for "3" ranges.	1	1	
4	DC ANALOG		None	None	
21	OVER RANGE	Indicates that ME-526A/USM range should be increased	0	1	
20	UNDER RANGE	Indicates that ME-526A/USM range should be decreased.	0	1	
2	-dBm	Not used.			
W	ENCODE COMPL	Indicates completion of encode cycle; data output may be read.	1	1	
17 18 19	4 } 2 } 1 } RANGE CODE	Indicates range selected in binary code; 0-1 mV range, 7 = 3000 mV range.	1	1	
F E D C	8 } 41 } ENCODE 2 } DATA 1 } DATA		Data in serial form, continuously scanned, left (MSD) to right, 500 us digit, 2 ms scan	1	1
H J K L	4 } 3 } Digit 2 } Select 1 }			; Indicates digit to which BCD data applies 4 = MSD(left-most).	1
		1			1
		1			1
		1	1		

• **Output Characteristics**

<i>TTL Series</i>	<i>Logic Level</i>	<i>Voltage Level</i>	<i>Current per Unit Load</i>
Standard Power 52/74	0	less than 0.7 V	1.6 mA
	1	2.4 to 5.25 V *	- 40 uA

*The "-" current indicates current sourced by output.

CHAPTER 3

OPERATOR MAINTENANCE

			<i>Page</i>
Section.	I.	General Operator Maintenance	3-1
Section.	II.	Troubleshooting Procedures.....	3-2

Section I. General Operator Maintenance

CLEANING

Use a mild soap or detergent and water. With a clean cloth dampened, not soaked, clean the front panel, switches, meter glass, top and bottom covers and rear panel.

ROUTINE CHECKS

- Check controls for smooth operation and tightness of knobs without binding.
- Check switches for positive action.
- Check connectors for proper seating.
- Check cables for cuts, cracks and other signs of deterioration.

Section II. Troubleshooting Procedures

TROUBLESHOOTING

• Introduction

1. The table lists the common malfunctioning which you may find during the operation or maintenance of the ME-526A/USM. You should perform the tests/inspections and corrective actions in the order given.
2. This manual cannot list all malfunctions that may occur, nor all tests or inspections and corrective actions. If a malfunction is not listed or is not corrected by listed corrective action, notify your supervisor.

MALFUNCTION	<i>TEST OR INSPECTION</i> • <i>CORRECTIVE ACTION</i>
<p>1. NO DISPLAY INDICATION, NO DBM METER MOVEMENT WHEN OFF-MV SWITCH PLACED IN MV POSITION.</p>	<p>Step 1. Check for ac power. • Verify ac power present</p> <p>Step 2. Check fuse. • Verify fuse not open.</p>
<p>2. CANNOT ZERO DISPLAY AND DBM METER WITH ZERO CONTROL.</p>	<p>Step 1. Check that FULL SCALE 1 mV pushbutton switch is depressed. • Verify 1 m V pushbutton Is depressed.</p> <p>Step 2. Check front panel PROBE connector for proper connection of RF PROBE. • Verify PROBE connector is secure.</p> <p>Step 3. Check that there is no rf input and the 50-OHM ADAPTER is attached to the RF PROBE. • Verify input removed. Attach 50-OHM ADAPTER.</p>
<p>3. INDICATOR DISPLAY IS KNOWN TO BE INCORRECT.</p>	<p>Step 1. Check connection made to signal under test.</p> <p style="text-align: center;">CAUTION</p> <p>When the RF PROBE must be replaced send the ME-526A/USM to higher level maintenance. The ME-526A/USM must be calibrated with the RF PROBE with which it is used.</p> <p>Step 2. Check RF PROBE tip (if used) for proper connection to RF PROBE. • Verify RF PROBE tip makes connection to RF PROBE. Replace tip if faulty. If RF PROBE is faulty, higher level maintenance required.</p>

APPENDIX A

REFERENCES

A-1. SCOPE

This appendix lists forms, field manuals, technical manuals and miscellaneous publications referenced in this manual.

A-2. FORMS

DA FORM 2028 Recommended Changes to Publications and Blank Forms.
DA FORM 2028-2 Recommended Changes to Equipment Technical Publications.
SF 368 Quality Deficiency Report.

A-3. FIELD MANUALS

FM 21-11 Artificial Respiration.

A-4. TECHNICAL MANUALS

TM 11-625406044P Organizational Direct Support and General Support Maintenance Repair Parts and Special Tools List for Meter, RF Millivolt ME-526A/USM (NSN 6625-01-161-1461).

A-5. MISCELLANEOUS PUBLICATIONS

DA PAM 310-1 Consolidated Index of Army Publications and Blank Forms.
DA PAM 738750 The Army Maintenance Management System.

A-1/A-2 (blank)

APPENDIX B**COMPONENTS OF END ITEM AND BASIC ISSUE ITEMS LISTS****Section I. Introduction****B-1. SCOPE**

This appendix lists components of end item and basic issue items for the ME-526A/USM to help you inventory items required for safe and efficient operation.

B-2. GENERAL

The Components of End Item and Basic Issue Items Lists are divided into the following sections:

a. Section II. Components of End Item. This listing is for information purposes only, and is not authority to requisition replacements. These items are part of the end item, but are removed and separately packaged for transportation or shipment. As part of the end item, these items must be with the end item whenever it is issued or transferred between property accounts. Illustrations are furnished to assist you in identifying the items.

b. Section III. Basic Issue Items. Not applicable.

B-3. EXPLANATION OF COLUMNS

The following provides an explanation of columns found in the tabular listings:

a. Column (1) - Illustration Number (Illus Number). This column indicates the number of the illustration in which the item is shown.

b. Column (2) - National Stock Number. Indicates the National stock number assigned to the item. The National stock numbers in section III will be used for requisitioning basic issue items.

c. Column (3) - Description. Indicates the National item name and, if required, a minimum description to identify and locate the item. The last line for each item indicates the FSCM (in parentheses) followed by the part number

d. Column (4) - Unit of Measure (U/M). Indicates the measure used in performing the actual operational/maintenance function. This measure is expressed by a two-character alphabetical abbreviation (e.g., ea., in, pr).

e. Column (5) - Quantity required (Qty Rqd). Indicates the quantity of the item authorized to be used with/on the equipment.

By Order of the Secretary of the Army:

Official:

JOHN A. WICKHAM JR.
General, United States Army
Chief of Staff

DONALD J. DELANDRO
Brigadier General, United States Army,
The Adjutant General

DISTRIBUTION:

To be distributed in accordance with DA Form 12-36 literature requirements for ME-526A/USM.

*U.S. GOVERNMENT PRINTING OFFICE : 1993 O - 342-421 (062844)

RECOMMENDED CHANGES TO EQUIPMENT TECHNICAL PUBLICATIONS



THEN... JOT DOWN THE DOPE ABOUT IT ON THIS FORM, CAREFULLY TEAR IT OUT, FOLD IT AND DROP IT IN THE MAIL!

SOMETHING WRONG WITH THIS PUBLICATION?

FROM: (PRINT YOUR UNIT'S COMPLETE ADDRESS)

DATE SENT

PUBLICATION NUMBER

TM 11-5825-270-10

PUBLICATION DATE

23 Jul 81

PUBLICATION TITLE

Radio Frequency R-2176/FRN

BE EXACT... PIN-POINT WHERE IT IS

PAGE NO.	PARA-GRAPH	FIGURE NO.	TABLE NO.

IN THIS SPACE TELL WHAT IS WRONG AND WHAT SHOULD BE DONE ABOUT IT:

TEAR ALONG PERFORATED LINE

PRINTED NAME, GRADE OR TITLE, AND TELEPHONE NUMBER

SIGN HERE:

DA FORM 2028-2 JUL 79

PREVIOUS EDITIONS ARE OBSOLETE.

P.S.—IF YOUR OUTFIT WANTS TO KNOW ABOUT YOUR RECOMMENDATION MAKE A CARBON COPY OF THIS AND GIVE IT TO YOUR HEADQUARTERS.

